

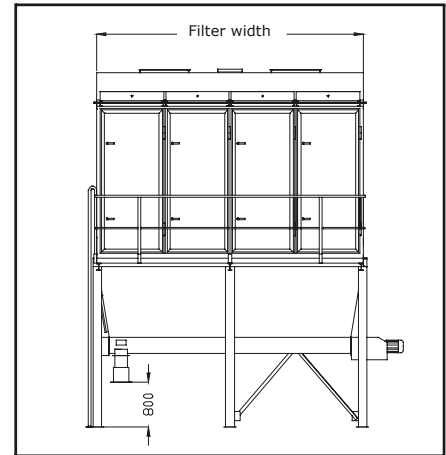

## NFD 7 Surface filter with compressed air cleaning

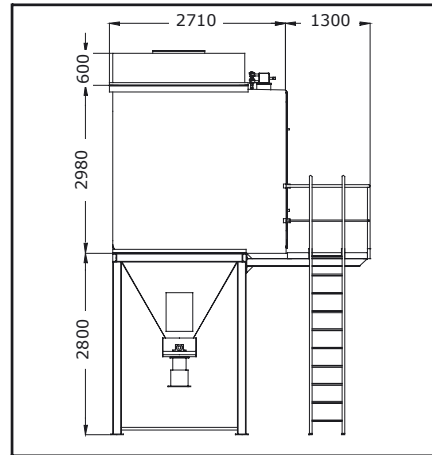
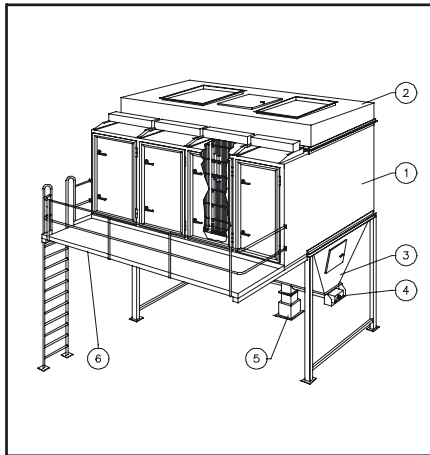

The NEOTECHNIK surface filter NFD operates fully automatically with a compressed air cleaning system. This custom-made filter allows

economic operation with a constantly low filter differential pressure. Compared to the reverse air filter the capital expenditure is consi-

derably lower. The control of the cleaning impulses is carried out electro-pneumatically. Impulse and interval times can be regulated.

Type	Filter bags quantity	Filter surface m <sup>2</sup>	Filter width mm	Weight kg
NFD 701	84	126	811	3 600
NFD 710	126	189	1 153	4 200
NFD 702	168	252	1 552	4 900
NFD 711	210	315	1 894	5 500
NFD 720	252	378	2 236	6 100
NFD 712	294	441	2 635	6 800
NFD 721	336	504	2 977	7 500
NFD 730	378	567	3 319	8 300
NFD 722	420	630	3 718	9 100
NFD 731	462	693	4 060	9 700
NFD 740	504	756	4 402	10 400
NFD 732	546	819	4 801	11 100
NFD 741	588	882	5 143	11 800
NFD 750	630	945	5 485	12 400
NFD 742	672	1 008	5 884	13 100
NFD 751	714	1 071	6 226	14 000
NFD 760	756	1 134	6 568	14 700
NFD 752	798	1 197	6 967	15 400
NFD 761	840	1 260	7 309	16 000
NFD 770	882	1 323	7 651	16 700
NFD 762	924	1 386	8 050	17 500
NFD 771	966	1 449	8 392	18 100
NFD 780	1 008	1 512	8 734	18 800
NFD 772	1 050	1 575	9 133	19 700
NFD 781	1 092	1 638	9 475	20 400
NFD 790	1 134	1 701	9 817	21 000
NFD 782	1 176	1 764	10 216	21 800
NFD 791	1 218	1 827	10 558	22 400

### Construction

The filter housing is constructed of reinforced welded steel sheet. Airtight doors allow access to the clean gas chamber. The filter element consists of individual filter bags and inserts with spanners. The filter elements, stretched via locking fastener, are easy to maintain and can be removed from the front.

In particular the cleaning device consists of:

- q Easy to dismantle nozzle pipes
- q Membrane valves
- q Valve control units
- q compressed air manifold

The filter unit is composed of the following premounted elements:

- 1 Filter housing
- 2 Crude gas hood
- 3 Dust collection hopper
- 4 Screw conveyor
- 5 Dust valve
- 6 Platform with access ladder



Examples of dust extraction:

- 1 Pneumatic dust transport
- 2 Manufacturing of cigarettes
- 3 Leaf tobacco processing
- 4 Tobacco processing (primary)
- 5 Dust collecting of dryer
- 6 Cleaning plant / Steel foundry



## NEOTECHNIK GmbH Entstaubungsanlagen

Piderits Bleiche 8 • D-33689 Bielefeld • Postfach 11 02 61 • D-33662 Bielefeld  
 Tel.: +49 (0) 52 05 75 03-0 Fax.: +49 (0) 52 05 75 03-77  
 Internet: [www.neotechnik.com](http://www.neotechnik.com) E-Mail: [info@neotechnik.com](mailto:info@neotechnik.com)